

Specifications :

ICE 815C

Eccentric moment	46 kgm	Clamps:	
Max. centrifugal force	1250 kN	Sheet pile clamp	160TU
Max. frequency	1570 rpm	Transport weight per piece	1100 kg
Max. amplitude excl. 160TU	23,3 mm	Double clamps	81TC
Max. amplitude incl. 160TU	18,2 mm	Transport weight per piece	480 kg
Max. static line-pull	400 kN		
Max. operating pressure	350 bar	Powerpack:	
Max. oil flow	610 l/min	Model	600 series
Forced lubrication	yes		
Dynamic weight excl. 160TU	3950 kg	Hose set:	
Dynamic weight incl. 160TU	5050 kg	Length	45 m
Total weight excl. 160TU & hoses	7450 kg	Transport weight (±)	983 kg

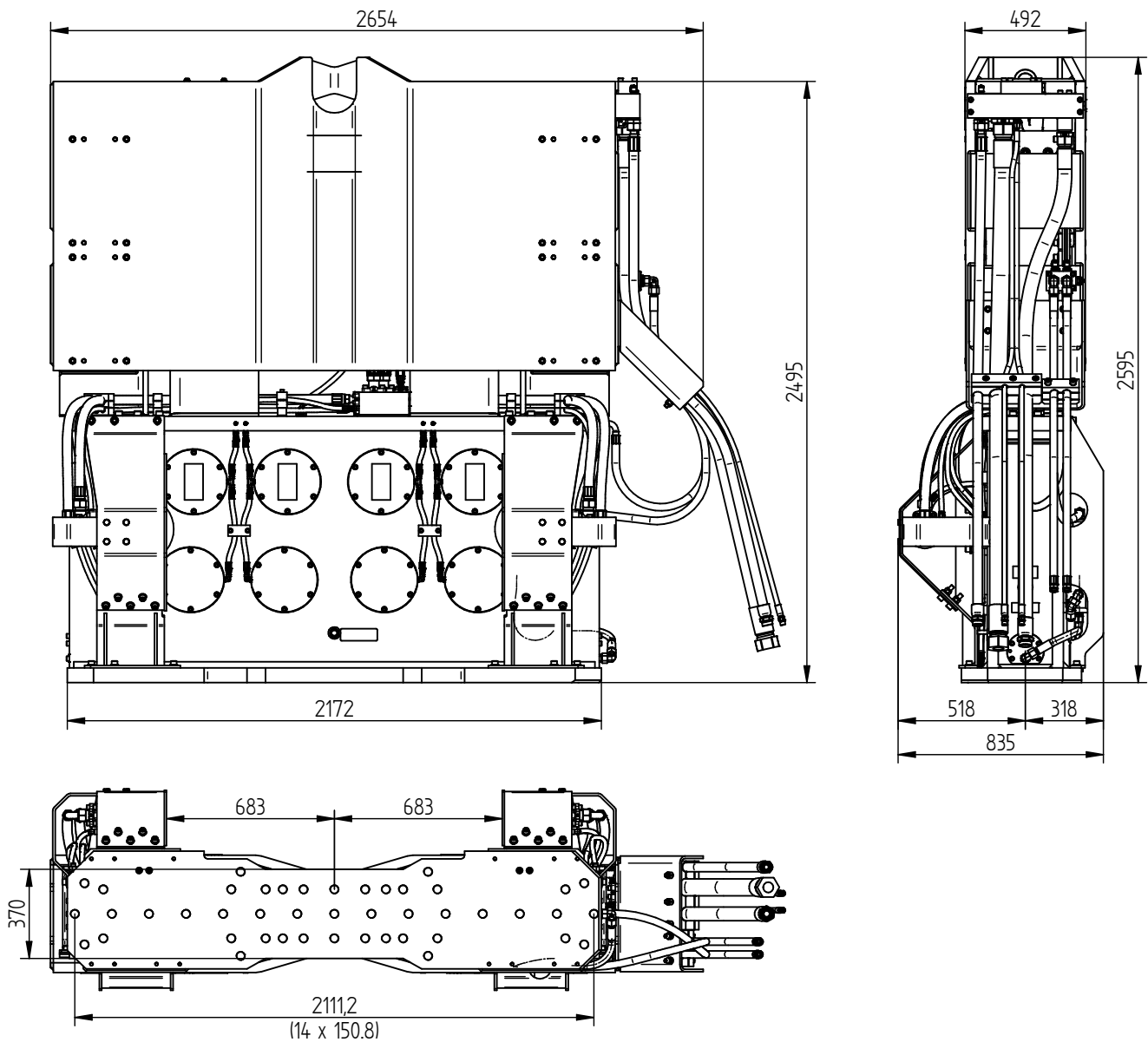

Technische Daten :

ICE 815C

Statisches Moment	46 kgm	Klemmzange:	
Max. Fliehkraft	1250 kN	Universalzange	160TU
Max. Drehzahl	1570 rpm	Transportgew. pro Stück	1100 kg
Max. Amplitude ohne 160TU	23,3 mm	Rohrklemmzange	81TC
Max. Amplitude mit 160TU	18,2 mm	Transportgew. pro Stück	480 kg
Max. Statische Zugkraft	400 kN		
Max. Betriebsdruck	350 bar	Aggregat:	
Max. Fördermenge	610 l/min	Modell	600 series
Zwangsschmierung	ja		
Dyn. Gewicht ohne 160TU	3950 kg	Schlauchsatz:	
Dyn. Gewicht mit 160TU	5050 kg	Länge	45 m
Gesamtgew. Ohne 160TU & Schläuche	7450 kg	Transportgewicht (±)	983 kg

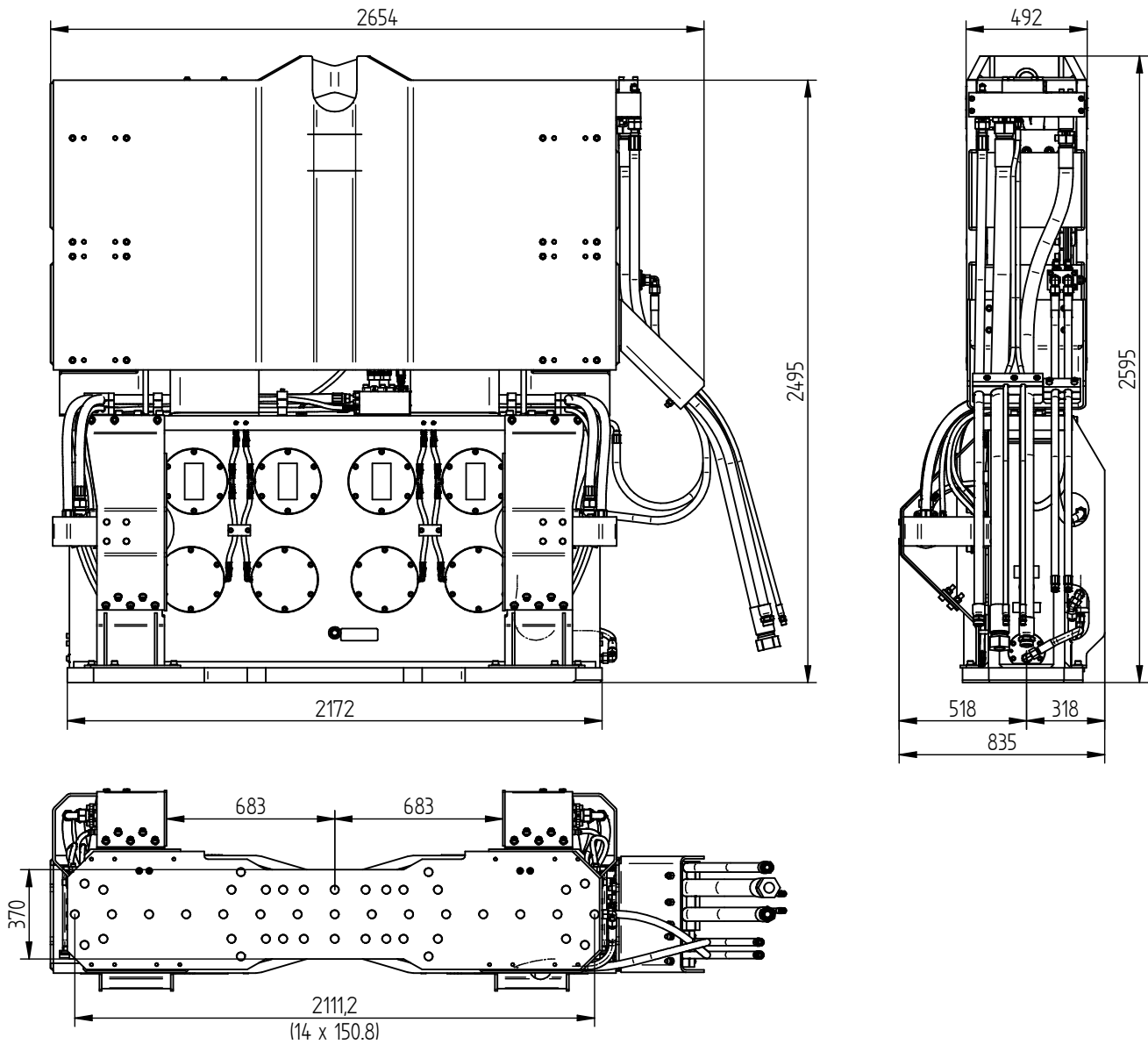

Spécifications

ICE 815C

Moment excentrique	46 kgm	Pinces:	
Max. force centrifuge	1250 kN	Pince palplanche	160TU
Max. fréquence	1570 rpm	Poids de transport par pièce	1100 kg
Max. amplitude sans 160TU	23,3 mm	Pince tube	81TC
Max. amplitude avec 160TU	18,2 mm	Poids de transport par pièce	480 kg
Force de traction statique	400 kN		
Pression de travail max.	350 bar	Groupe hydraulique:	
Débit d'huile max.	610 l/min	Modèle	600 series
Huile lubrifiante	oui		
Poids dynamique sans 160TU	3950 kg	Jeu de tuyau:	
Poids dynamique avec 160TU	5050 kg	Longueur	45 m
Poids total sans 160TU & tuyaux	7450 kg	Poids de transport (±)	983 kg

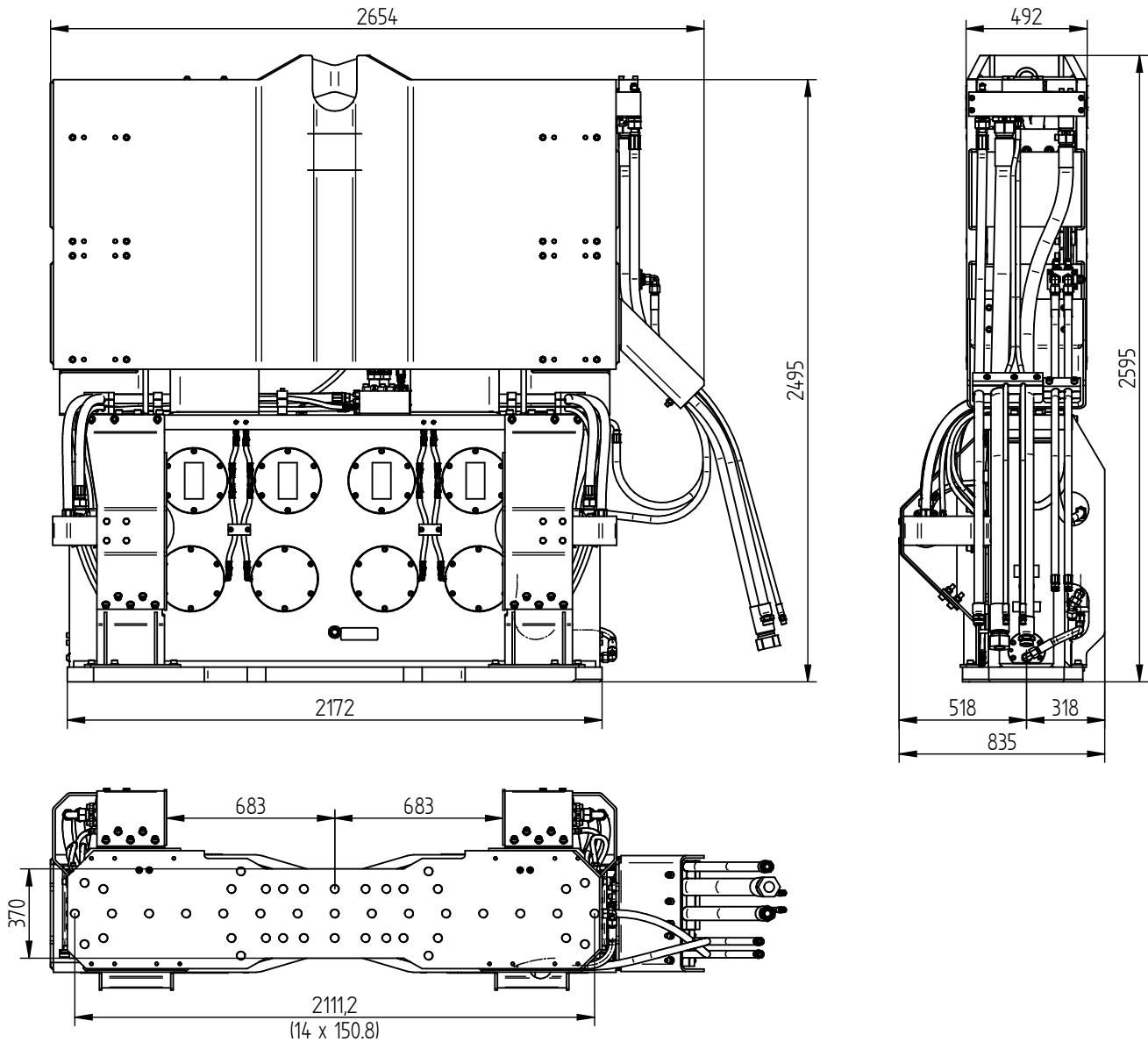

Specificaties

ICE 815C

Excentrisch moment	46 kgm	Klemmen:	
Max. centrifugaalkracht	1250 kN	Damwandklem	160TU
Max. toerental	1570 rpm	Transportgewicht per klem	1100 kg
Max. amplitude excl. 160TU	23,3 mm	Pijpenklem	81TC
Max. amplitude incl. 160TU	18,2 mm	Transportgewicht per klem	480 kg
Max. statische trekkracht	400 kN		
Max. werkdruk	350 bar	Aggregaat:	
Max. oliedoorstroming	610 l/min	Model	600 series
Geforceerde smering	ja		
Dynamisch gewicht excl. 160TU	3950 kg	Slangenset:	
Dynamisch gewicht incl. 160TU	5050 kg	Lengte	45 m
Totaalgewicht excl. 160TU & slangen	7450 kg	Transportgewicht (±)	983 kg

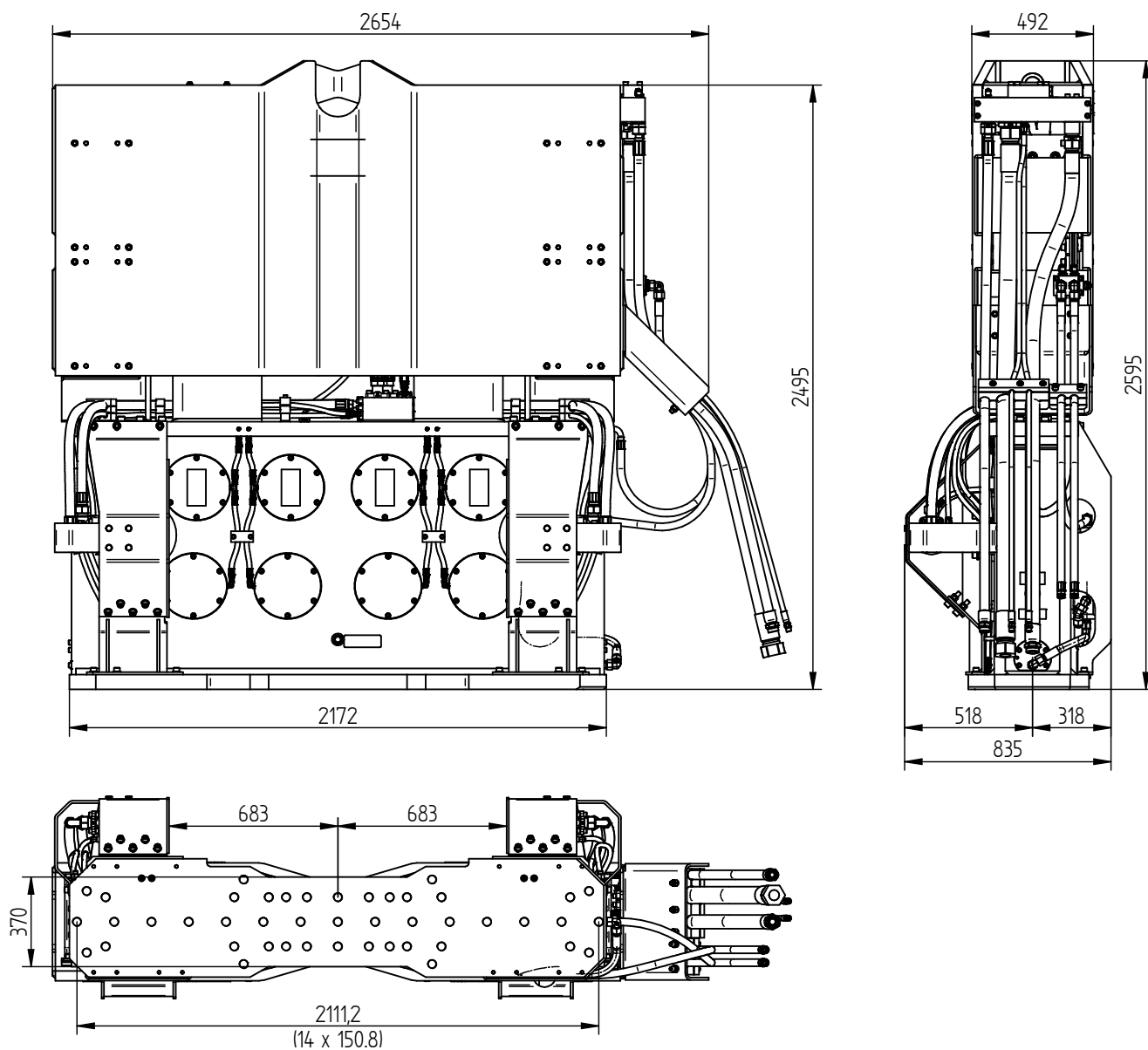

Especificaciones

ICE 815C

Momento excéntrico	46 kgm	Abrazadera:	
Fuerza centrífuga máxima	1250 kN	Hoja abrazadera pila	160TU
Frecuencia máxima	1570 rpm	Peso de transporte por pieza	1100 kg
Amplitud máxima excluyendo 160TU	23,3 mm	Abrazadera de tubo	81TC
Amplitud máxima incluyendo 160TU	18,2 mm	Peso de transporte por pieza	480 kg
Estático tracción máxima	400 kN		
Presión máxima de trabajo	350 bar	Unidad de potencia:	
Flujo de aceite máximo	610 l/min	Modelo	600 series
Lubricación forzada	si		
Peso dinámico excluyendo 160TU	3950 kg	Conjunto de manguera:	
Peso dinámico incluyendo 160TU	5050 kg	Longitud	45 m
Peso total excluyendo 160TU & mangueras	7450 kg	Peso de transporte (±)	983 kg

Dimensions in inches

USA

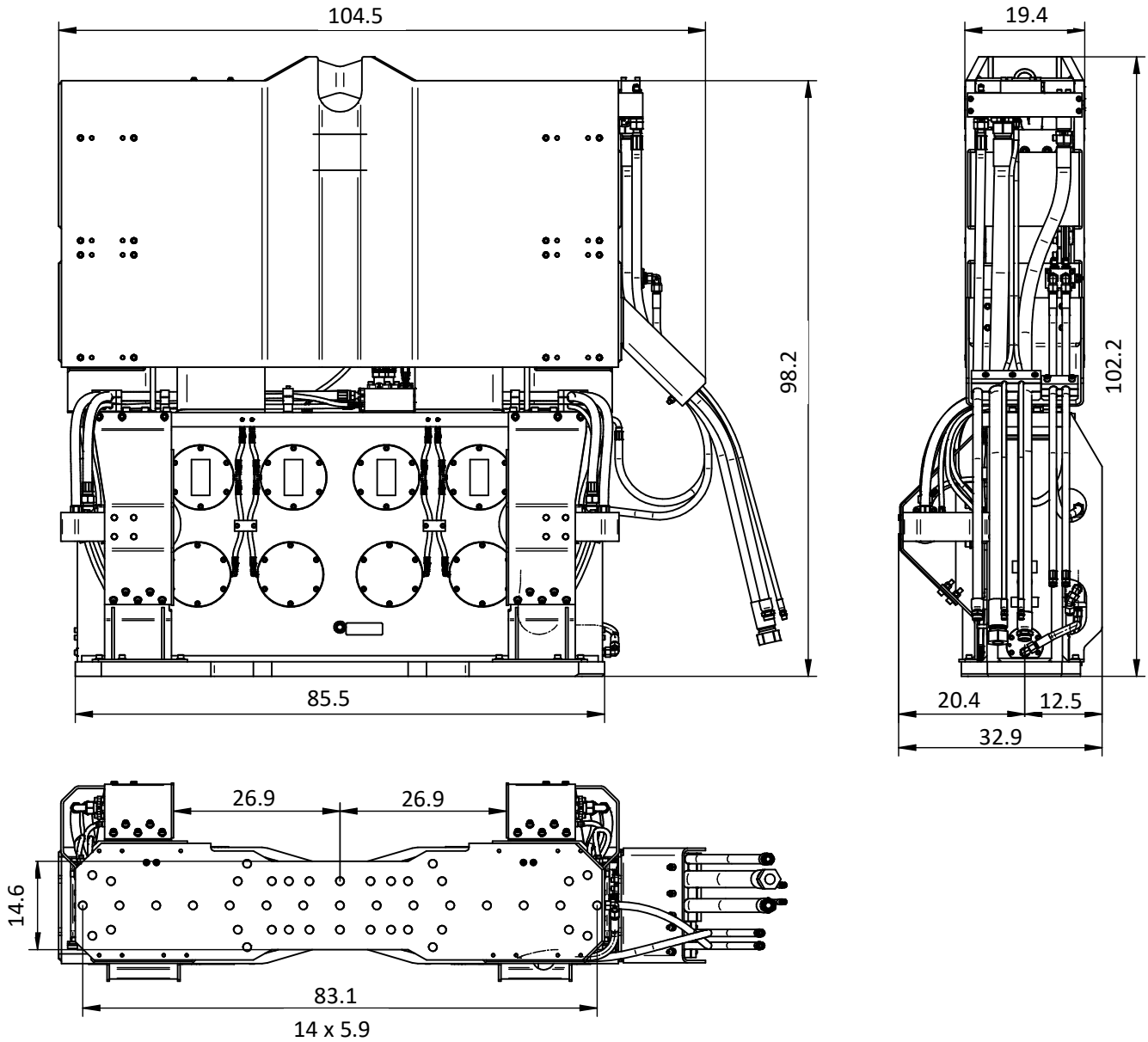

Specifications

ICE 815C

Eccentric moment	3,993 in-lbs	Clamps:	
Max. centrifugal force	141 ton	Sheet pile clamp	160TU
Max. frequency	1,570 rpm	Transport weight per piece	2,425 lbs
Max. amplitude excluding 160TU	0.92 in	Double clamps	81TC
Max. amplitude including 160TU	0.72 in	Transport weight per piece	1,058 lbs
Max. static line-pull	41 ton		
Max. operating pressure	5,076 psi	Powerpack:	
Max. oil flow	161 gal/min	Model	600 series
Forced lubrication	yes		
Dynamic weight excluding 160TU	8,708 lbs	Hose set:	
Dynamic weight including 160TU	11,133 lbs	Length	148 ft
Total weight excluding 160TU & hoses	16,424 lbs	Transport weight (±)	2,167 lbs

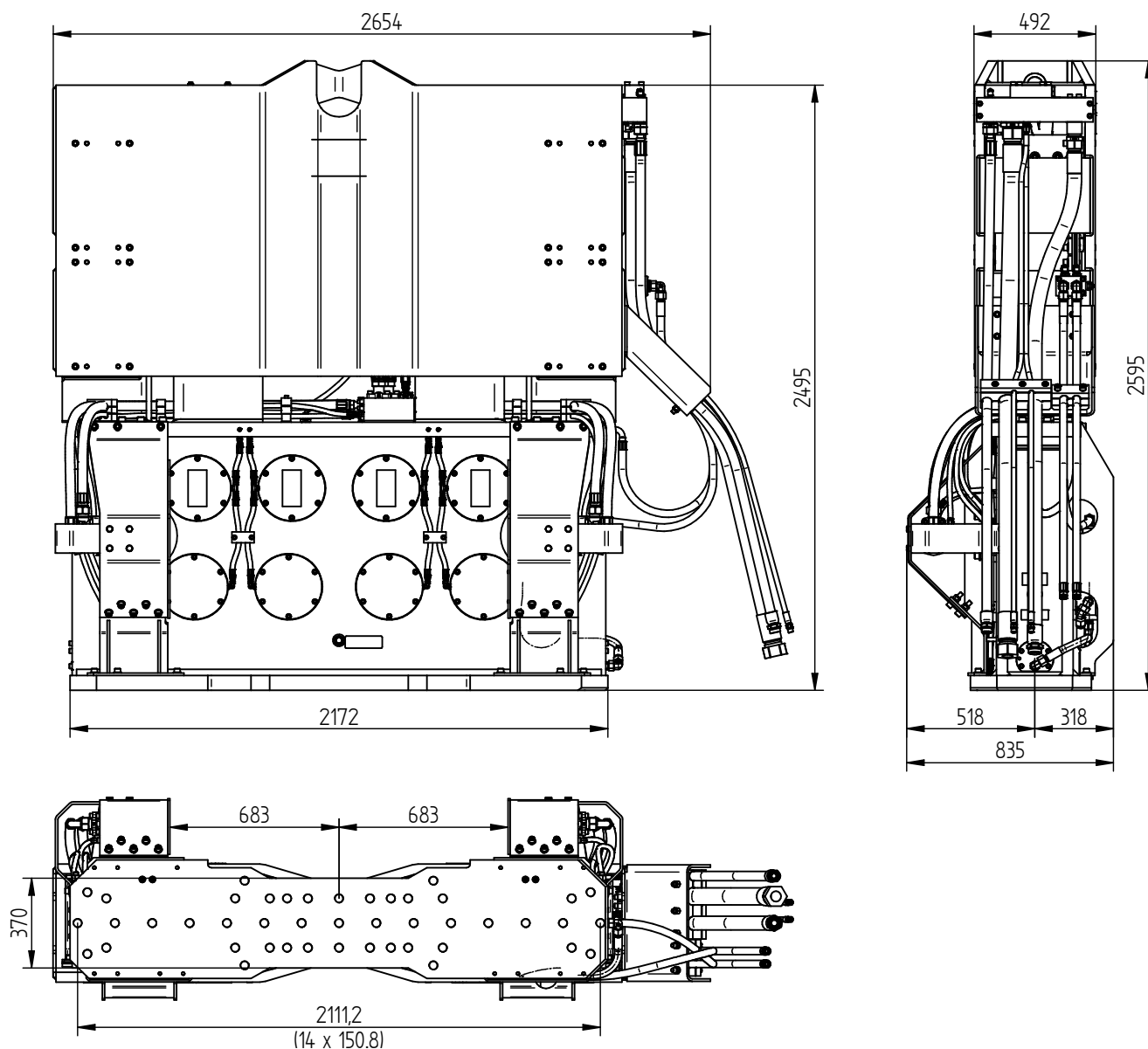

Specificatii :

ICE 815C

Moment excentric	46 kgm	menghira:	
Forta centrifuga maxima	1250 kN	menghina pentru palplanse	160TU
Frecventa maxima	1570 rpm	Greutatea de transport pp.	1100 kg
Amplitudine maxima exclusiva. 160TU	23,3 mm	menghina dubla	81TC
Amplitudine maxima inclusivă. 160TU	18,2 mm	Greutatea de transport pp.	480 kg
Tractiune maxima statica	400 kN		
Presiune maxima de lucru	350 bar	generatoare:	
Debit maxim de ulei	610 l/min	Model	600 series
Lubrifiere fortata	da		
Greutatea dinamica exclusiva. 160TU	3950 kg	Tip de furtun:	
Greutatea dinamica inclusivă. 160TU	5050 kg	Lungimea	45 m
Greutatea totala fara. 160TU si furtun	7450 kg	Greutatea de transport (±)	983 kg